

Logo  
Lites<sup>®</sup>



## Third Brake Light Installation Guide Vintage Standard Series

Consumer Hot Line: 888-471-LOGO  
770-476-7322 In Atlanta, GA  
<http://www.logolites.com>

---

P/N: 100-0008/B

©2003  
Creative Connections, Inc.  
3407 Hwy. 120  
Duluth, GA 30096, USA

“Logo Lites” and the Logo Lites  
logo are registered trademarks of  
Creative Connections, Inc.



## Table Of Contents

<b>Introduction</b>	<b>2</b>
Safety Information	2
Tools Needed	2
<b>Overview</b>	<b>3</b>
<b>Hardware Components</b>	<b>3</b>
<b>Installation</b>	<b>3</b>
Step 1: Choose Your Configuration	3
Step 2: Assemble the Inclinometer	4
Step 3: Level the Car	4
Step 4: Measure the Rear Window Angle	4
Step 5: Cut the Blinders	5
Step 6: Assemble the Blinders	6
Step 7: Assemble Third Brake Light	6
Step 8: Prepare the Parts for Mounting	8
Step 9: Mount the Light Assembly	8
Step 10: Route the Wires	10
Step 11: Make the Electrical Connections	10
<b>Replacement parts guide</b>	<b>11</b>
<b>Trouble Shooting</b>	<b>12</b>
<b>Limited Warranty</b>	<b>12</b>

## INTRODUCTION

Thank you for purchasing a Logo Lites® LED Third Brake Light Kit. Your third brake light kit was built to high quality standards to provide you with years of reliable service. This manual should serve as a guide for installing a third brake light kit on your vehicle. Although this guide is thorough, each installation is different, so it cannot cover all applications. You can install the turn signal kit yourself IF:

1. you have the right tools,
2. you have a reasonable mechanical and electrical aptitude or experience,
3. you have the knowledge or diagrams of where wiring, fuel lines, etc. are located in the vehicle,
4. and you read and follow the instructions very carefully.

### SAFETY INFORMATION

- Read the instructions completely before starting the installation of your third brake light kit.
- Never attempt automobile wiring without first disconnecting the battery from the chassis.
- When using power tools such as a drill, be sure to use the proper safety equipment (eye protection, etc.). Always follow manufacturer's recommendations when using power and hand tools.
- **The installation discussed is for reference only and does not indicate that any particular configuration will be safe for all vehicles. A safe and secure installation is solely the responsibility of the installer!!**

### TOOLS NEEDED

- ◆ Common wrenches and screwdrivers
- ◆ Wire crimp tool
- ◆ Wire cutter
- ◆ Wire stripper

## OVERVIEW

This kit provides all the necessary parts to install a Logo Lites ® LED Third Brake Light Kit on your antique car or truck. Vintage Standard Series Logo Lites LED Third Brake Lights mount to the vehicle so that the light faces out of the back window. The wires connect to the brake light power wire and the chassis. The third brake light works on 6 or 12 Volt cars with positive or negative ground.

## HARDWARE COMPONENTS

Qty	Item	Qty	Item	Qty	Item
1	LED Third Brake Light	10	#8 Self Tapping Screws	2	ABS Window Mounts
15'	Red & Black Wire	5	#8 Machine Screws	1	ABS Rear Mount
1	Fuse Holder	5	#8 Machine Nuts	1	ABS Package Tray Mount
1	1 Amp Fuse	1	#8 Tooth Washer	2	Side Mounts
1	#8 Ring Terminal	1	ABS Pointer	1	ABS Short Suspension Arm
1	Large Ring Terminal	1	ABS Inclinometer	2	Medium Suspension Arms
1	Hex Driver	1	ABS Bottom Blinder	1	ABS Long Suspension Arm
1	Blue T-Tap	2	ABS Side Blinders	1	Manual
1	Red Quick Disconnect	2	ABS Binding Channels		

## INSTALLATION

### STEP 1: CHOOSE YOUR CONFIGURATION

You can install your third brake light many different ways. Before proceeding any further, you must decide where and how you will mount yours.

The LEDs used in your Logo Lites third brake light are extremely bright. Logo Lites third brake lights come with anti-glare blinders. These blinders are provided to help prevent the emitted light from re-entering the passenger compartment.

Figure 1 shows just a few of the possible configurations for your Logo Lites auxiliary brake light. These examples are as follows:

1. Roof mounted light with steep rear window
2. Rear mounted light in pick up truck or antique car (no blinders)
3. Window mounted light with medium slope
4. Package tray mount with medium slope window
5. Window mount on vertical window (no blinders)
6. Window mount with very low slope window

When deciding the best configuration for your vehicle, consider where you are going to route the wires, where wire holes will be drilled, where you will be connecting to the brake light wire harness, etc.

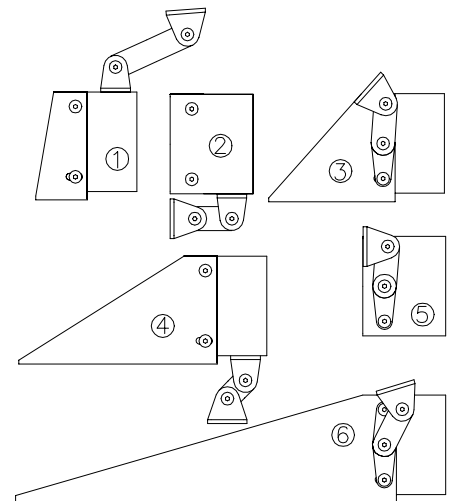

**Figure 1 - Example**

## NIGHT TIME DRIVING WARNING!

If your Logo Lites auxiliary brake light is not mounted with the whole face completely touching the window, and is not installed correctly with the blinders supplied, be aware that the back window of your car will become very bright when the brakes are applied at night. This can impair a driver's night time vision. Impaired vision can cause a serious or fatal accident.

If you are not using the blinders, proceed to "Step 7 Assemble Third Brake Light."

### STEP 2: ASSEMBLE THE INCLINOMETER

To begin the installation with blinders, you must assemble a tool that is provided in the kit called an inclinometer. This tool measures angles and it is used here to determine the angle of your back window. Locate the inclinometer and the pointer in the plastic parts kit. Place the pointer on the front of the inclinometer. Insert a #8 machine screw through the hole in the top and secure them with a #8 machine nut on the back. Leave the screw a little loose so that the pointer can rotate freely. When assembled, they should look like Figure 2. To measure an angle, hold the top or bottom of the inclinometer against what you are measuring.

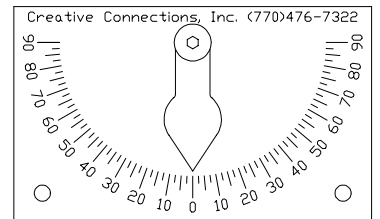

Figure 2 - Inclinometer

### STEP 3: LEVEL THE CAR

The next step is to level the car. The car must be level from front to back as a minimum. The bottom of the doorjamb, under the door, is usually parallel to the axis of the car. Use this area (shown by the arrow in Figure 3) to check for level with the inclinometer. Once level, unless you have a modified vehicle, the inclinometer will point at 0°.

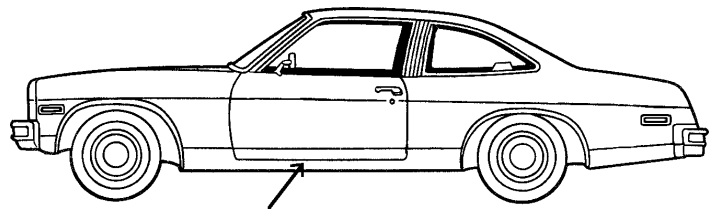

Figure 3 - Bottom of Door Jamb

### Special Information about Modified Vehicles

If your car has been modified with larger tires in the back than in the front, air shocks, lowered front end, etc. then you should drive the vehicle onto a level surface. The bottom of the doorjamb shown in Figure 3 will **not** be level on a car that is modified in this way.

### STEP 4: MEASURE THE REAR WINDOW ANGLE

You must measure the rear window angle where you will be mounting the light. Do this by holding the top of the inclinometer against the inside of the window in the selected location. **If your car is a hatch-back, it must be in the closed position.** If you cannot reach the position to measure it, or it is difficult to read the inclinometer, you can place the bottom of the inclinometer on the outside of the glass in the correct location and measure the angle. Write down the angle here \_\_\_\_\_ for reference later.

### Inclinometer Hints:

- If the numbers are hard to read on the face of the inclinometer, rub a piece of white chalk against the face. Wipe the chalk off the face leaving the chalk in the numbers. This will "highlight" the numbers.

- When measuring angles with the inclinometer, tilt the top of the face toward you a little to make the pointer move easier. Tap gently on the face of the inclinometer to make measurements that are more accurate. If it still does not move easily, loosen the nut a little.

### STEP 5: CUT THE BLINDERS

Use the angle you wrote down in “Step 4: Measure the Rear Window Angle” on page 4 and the information shown in Table 1 to locate the proper position to cut. Follow the instructions below on how to cut the blinders in the correct grooves.

#### Side Blinders

Be careful when cutting the blinders! On the side with the grooves, locate the two numbers in the large groove at the bottom. You will have to cut the blinders in the small groove located between these two numbers. It is usually easiest to turn the blinder so that the numbers are read upside down and then pull the blade, away from your other hand and your body as shown in Figure 4. Be sure to keep your fingers away from where you are cutting! If you rush, the blade may jump out of the small groove and can cut you. Use many strokes rather than high pressure. For best results, it may take 20 to 30 light strokes of the blade to cut all the way through the blinder.

#### Bottom Blinder

Repeat the same procedure as the side blinders for the bottom blinder. Again, cut the blinder between the numbers shown in the chart. More time and care should be taken cutting the bottom blinder because it is more visible once mounted in the car. If your blade jumps out of the groove when you are cutting the bottom blinder, a scar may be left on the visible surface.

#### Blinder Tip:

- If you use too much force while cutting or you break the blinders, there will be a white area on the cut or broken edge. This can be polished with a wet #400 sandpaper to return most of the black appearance.

**Table 1 - Blinder Cut Guide**

Inclinometer Reading Between	Cut Groove Between Numbers:
13-21°	No cut
22-29°	8&9
30-37°	8&7
38-45°	7&6
46-53°	6&5
54-61°	5&4
62-69°	4&3
70-77°	3&2
78-85°	2&1
85-90°	Don't use blinder

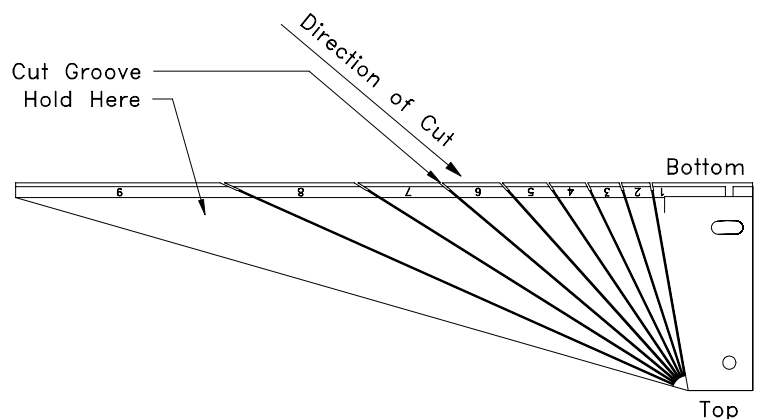

**Figure 4 - Blinder Cut Example**

## STEP 6: ASSEMBLE THE BLINDERS

The bottom blinder should loosely lock into the side blinders. Now take the binding channels, and slip them over the joint between the bottom and side blinders. If you cut the blinders, then the binding channels will be too long. Slide the binding channels all of the way to the end of the track. Make sure that the lock at the back of the bottom blinder is engaged into the side blinders. Using a single edge safety razor blade or similar cutting device, mark the binding channel where it protrudes from the blinders. Remove the binding channel and carefully cut it at the mark you just made with a safety razor blade or a pair of scissors. Now reverse the binding channel and re-assemble it with the blinders (reverse it so that the cut end goes on first - this will hide the cut against the lock/stop).

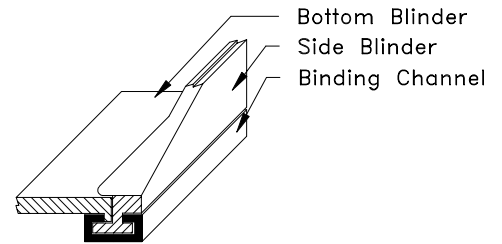

Figure 5 - Assembled Blinders

## STEP 7 ASSEMBLE THIRD BRAKE LIGHT

Look at the third brake light and be sure the red lens housing is flush or recessed into the case. If not, place the unit face down on a flat surface and press gently on the back of the case, until the case and lens housing are flush.

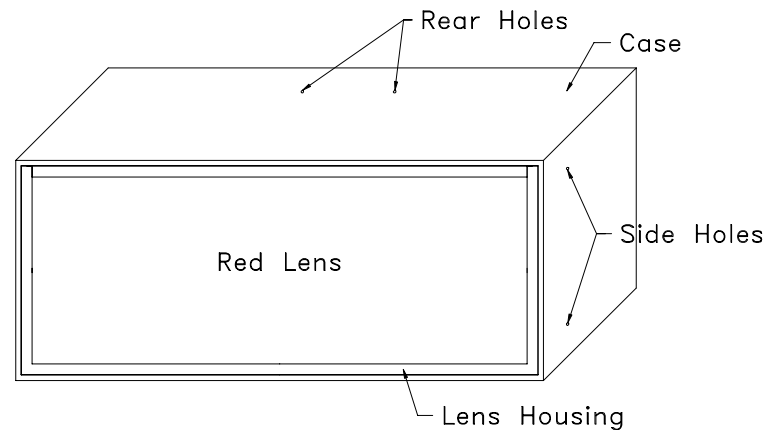

Figure 6 - Hole Locations

### Window Mounts

1. Thread four #8 self-tapping screws into the four side holes in the case using the hex driver (see Figure 6). Under the surface, the holes are much larger, and should thread easily once the screws are started. Once the screws have started, thread them down approximately three turns.
2. Remove the screws from the case. The holes are now threaded and will make later assembly easier. Carefully remove any flashing that may be sticking up from the case.
3. You must clean the window mounts on the flat surface where the adhesive tape will be applied (see Figure 7). First, clean them with a window cleaner and a clean lint free cloth. Next, clean the flat surface with one of the included alcohol pads. You can allow the alcohol on the window mounts to dry naturally, or use a clean, dry lint free cloth to dry them. **Do not blow on the surface to speed drying. Do not touch the flat surface of the window mount with your fingers after you have cleaned it. Finger oils left on the window mount will destroy the adhesive.**
4. Once the window mounts are clean and dry, you are ready to adhere the adhesive tape to the window mount as shown in Figure 7. The ideal adhesive tape application temperature range is 70°F to 100°F (21°C to 38°C). Minimum acceptable application surface temperature is 50°F (10°C). **Do not touch the adhesive side of the tape with your fingers. Finger oils will destroy the adhesive.** Remove the white side of the adhesive tape backing. Apply the uncovered side of the adhesive tape to plastic window mount. Press firmly for at least 30 seconds on a hard, smooth, flat surface such as a work bench. Bond strength is dependent upon the amount of adhesive-to-surface contact developed. Firm application pressure develops better adhesive contact and thus improves bond strength. Repeat the process for the second window mount.

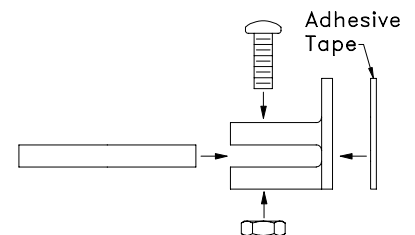
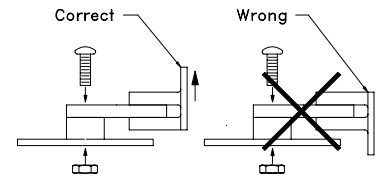

Figure 7 - Assemble Arm & Adhesive Tape to Window Mount

5. Using a #8 machine screw and a #8 machine nut, loosely assemble a medium length suspension arm to a window mount (as shown in Figure 7). Repeat for the second medium length suspension arm and window mount.
6. Using a #8 machine screw and a #8 machine nut, loosely assemble the other end of the suspension arm to a side mount. Make sure that the “foot” of the window mount is pointed away from the side mount, as shown in Figure 8. Repeat for the second arm and side mount.
7. If blinders are being used, attach the side mounts and blinders to the case with the four #8 self tapping screws as shown in Figure 9.
8. If blinders are not being used, attach the side mounts to the case with the four #8 self tapping screws.

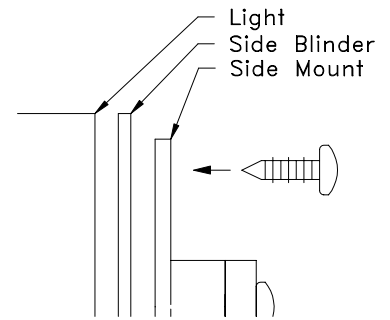

**Figure 8 - Assemble Arm to Side Mount**

**All Other Mounting Types**

Use this section only if you are not going to use a window mount as shown in drawings 1,2, or 4 in Figure 1 on page 3.

1. Thread four #8 self tapping screws into the four side holes (see Figure 6) on the case. Under the surface, the holes are much larger, and should be threaded easily once the screws are started. Thread them down until the heads of the screws are just touching the case.
2. Thread two #8 self tapping screws into the holes at the rear of the case. Thread either the top or bottom of the case depending on your configuration.
3. Remove the screws from the rear holes in the case. The holes are now threaded and will make later assembly easier. Carefully remove any flashing that may be sticking up from the case.
4. If you are using blinders, remove the screws from the side holes in the case. Again, carefully remove any flashing that may be sticking up from the case.
5. If blinders are being used, attach the blinders to the case with four #8 self tapping screws.
6. If you are using blinders and you are using the roof mount method, then go to #7. Otherwise, attach the rear mount to the case with two #8 self tapping screws.
7. Depending on your configuration, attach a small, medium, or large suspension arm to the rear mount as shown in Figure 10 using a #8 machine screw and nut.
8. Attach the other end of the suspension arm to the package tray mount using a #8 machine screw and nut as seen in Figure 11.
9. Assembled light should look somewhat like Figure 12.



**Figure 9 - Attach Blinders and Side Mounts**

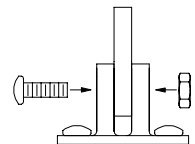

**Figure 10 - Rear Mount**

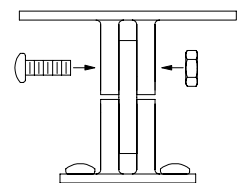

**Figure 11 - Package Tray Mount**



**Figure 12 - Completed Assembly**

## STEP 8: PREPARE THE PARTS FOR MOUNTING

### Set the Angle

If you are using the blinders, you have to set the angle of the box to the blinders. Tighten the four screws that are attaching the blinder to the case until a slight amount of pressure is required to adjust the blinder angle. Lay the loosely assembled unit down, on its face, on a level table or work bench (you can use the inclinometer to make sure the table is level). Use the side of the inclinometer to set the angle to the angle you measured in “Step 4: Measure the Rear Window Angle.” Tighten the angle adjusting screw and then the pivot screw on each side of the case so they are tight to each other and do not easily change angles. If you are using blinders and you are using the roof mount method, you may now attach the rear mount to the case.

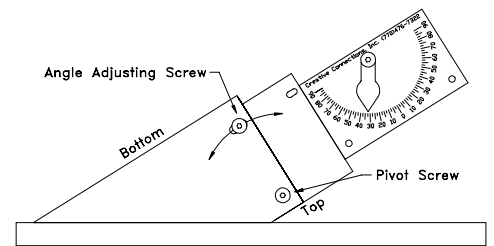

Figure 13 - Set Blinder Angle

### Set the Window Mounts

If you are using the blinders and a window mount configuration, lay the third brake light on its face as shown in Figure 14. Tighten the two pivot screws on each side so that the window mounts are flat to the workbench. Now the third brake light is prepared to be attached to the window. For both sides, firmly tighten the window mount to the suspension arm and the suspension arm to the side mount.

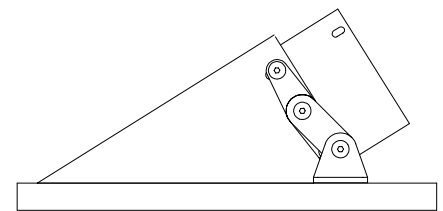

Figure 14 - Set Window Mount Positions

## STEP 9: MOUNT THE LIGHT ASSEMBLY

Remember, all vehicles are different. The information given on mounting are guidelines only. You really must take time and determine the best routine for mounting in your vehicle. Make sure the light is centered in the window from left to right for maximum visibility. For best driver visibility, the third brake light usually works best at the bottom of the window. If you are using blinders, then the blinders should make contact with the back window. If you have a vertical back window and you are not using blinders, then the face of the brake light should make contact with the window. Some minor tweaking of the two pivot screws on each side of the case may be needed to ensure full contact of the face of the blinders to the window.

**Note: For those installations where blinders are not required,** you should make sure that the back of the case is level when you complete this step.

### Window Mount

#### *Place the Template*

Tape the template on the outside of the glass so that the template is legible from the inside of the car and the square boxes are about where the window mounts of the unit are going to be placed. Use a tape measure to make sure that the template is aligned left to right and not tilted with respect to your vehicle. Place the assembled unit inside the car against the glass aligned with the template. If it does not look correct (level from side to side, centered in the vehicle, etc.) or it can not be mounted where the template is located, go outside the vehicle, move the template, and repeat. **You only get one chance to mount the double sided adhesive to the glass.** Therefore, practice putting the complete light assembly against the glass, until you can put the mounts in the correct position without having to shift them when you press the mounts to the glass.

### *Clean the Window*

If you are using the window mount method, thoroughly clean the areas of the window where the template shows the mounts will attach with a good window cleaner and a clean, lint free cloth. Also clean the area the auxiliary brake light will be visible through. After they are dry, clean the mounting areas again using the included alcohol wipes. Allow several minutes to completely air dry. Do not attempt to accelerate drying time. **Do not touch the surface of the window where the mount will attach after you have cleaned it. Finger oils left on the window will destroy the adhesive.**

### *Attach the Window Mounts*

While the window is drying, loosen the medium extension arms and window mounts just enough that they can be moved. This will allow the window mount to make better adhesion with the window when you press the mounts into place.

Once the window is dry, take the backing off of the adhesive tape on the window mounts. **Do not touch the adhesive side of the tape with your fingers. Finger oils will destroy the adhesive.** Apply the unit to the glass with even pressure for at least 30 seconds. Remember, the ideal adhesive tape application temperature range is 70°F to 100°F (21°C to 38°C). Minimum acceptable application surface temperature is 50°F (10°C). Bond strength is dependent upon the amount of adhesive-to-surface contact developed. Firm application pressure develops better adhesive contact and thus improves bond strength.

After the mounts have been pressed to the glass, press on the ribs of each window mount for another 30 seconds to increase contact on the “inside” of the window mounts. Then press on the “outer” section of the window mounts for 30 seconds with your thumbs. Go outside of the car and check the adhesive pads for continuous contact and repeat, pressing where necessary until full contact is achieved. Remember, you must press for at least 30 seconds in each area, or there will be no bonding.

Now lift the third brake light assembly to the window and tighten the window mount and medium suspension arm screws.

### *Allow Bonding Time*

**After application, the bond strength increases and approaches the ultimate bond strength after 72 hours at 70°F (21°C).** At 70°F (21°C), in 20 minutes, the bond strength will be 50%. After 72 hours, the bond strength will be 100%. At a temperature of 110°F (43°C), after 2 hours, the adhesive will be at 100% bond strength.

## **Package Tray Mount**

### *Drill the Holes*

Secure the template where you believe the unit will be mounted. Hold the unit against the template. Align the light to the template and check to see if the light is where you want it. If not, move the template and check again. Once you have determined that the template is in the correct place, drill the holes. Mounting holes should be 9/64” in diameter. Make sure you are drilling through metal. **Make sure that there are no wires, fuel lines, glass, or brake lines where you are making the holes.**

### *Clean the Window*

You should clean the area the auxiliary brake light will be visible through. Clean the window with a good window cleaner and a clean, lint free cloth.

## Roof Mount

### *Drill the Holes*

Secure the template where you believe the unit will be mounted. Hold the unit against the template. Align the light to the template and check to see if the light is where you want it. If not, move the template and check again. Once you have determined that the template is in the correct place, drill the holes. Mounting holes should be 9/64" in diameter. Make sure you are drilling through metal. **Be careful not to drill through the roof and check to make sure the screw is not too long. Make sure that there are no wires, fuel lines, glass, or brake lines where you are making the holes.**

### **STEP 10: ROUTE THE WIRES**

Remember, all vehicles are different. The information given on mounting are guidelines only. You really must take time and determine the best method for routing your wires in your vehicle. Although routing the wires can usually be done without drilling any holes, if you do decide to drill a hole, **make sure that there are no wires, fuel lines, glass, or brake lines where you are making the holes.** The easiest way to connect the third brake to power is to tap into the brake light wiring harness, usually near the brake lights. However, it may be easier in many vehicles to connect to the harness running to the brake lights inside the passenger compartment. Many coupes and sedans have easy access to the harness under the package tray, above the driver's side wheel well.

### **STEP 11: MAKE THE ELECTRICAL CONNECTIONS**

#### **Determine Your Chassis Polarity**

It is very important to determine if your vehicle is positive or negative chassis. Start by looking at your car's battery. There are two battery cables. One is connected from the battery to the starter. The other cable is connected from the battery to the chassis (frame) of the vehicle. The cable that connected to the chassis from the battery will indicate which polarity your chassis is. Look at the battery where the cable from the chassis connects. If there is a + marked on the battery, you have a **positive** chassis. If there is a - on that connection of the battery, you have a **negative** chassis. Once you have determined your chassis polarity, follow the appropriate instructions below. **CAUTION! -- Before proceeding any further, disconnect the side of the battery that connects to the chassis.**

#### **General Connection Information**

You will be splitting the two wires apart at the end connecting to the vehicle's harness. One will connect to the chassis and the other will connect to the wire providing power to the brake lights. The chassis connection can be made either by putting the provided large ring terminal under the head of a bolt that threads into a grounded metal member of the vehicle, or by drilling a 9/64" hole in the chassis and screwing a #8 self tapping screw, through the #8 star washer, and the #8 ring terminal.

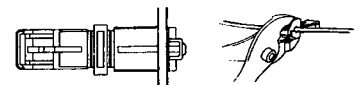

**Figure 15 - T-Tap Connector**

Determine where you are going to make your chassis and brake light wire connection. Cut the wire to a length that will allow both the chassis connection and the connection to the brake light wire. We suggest that you leave an extra inch or two of wire in length to make it easy to assemble. Cut the pair of wires apart approximately 1/4", then take one wire in each hand and slowly split the wires apart (like peeling a banana) until you have approximately 12" of the two wires split apart (you can split more if needed).

#### **Negative Chassis Electrical Connection**

**Red Wire:** Strip 0.250" - 0.375" (1/4" to 3/8") of insulation off the end of the red wire. Twist the conductor strands together. Insert the twisted conductors into the supplied red female quick connect

terminal until it stops. Where the wire goes into the crimp connector, the wire goes through a large barrel and then a small barrel. Using a crimping tool, crimp the wire in place in the small barrel. Next, crimp the outer most barrel (the large barrel) for mechanical strength.

**Black Wire:** Strip 0.250" - 0.375" (1/4" to 3/8") of insulation off the end of the black wire. Twist the conductor strands together. Insert the twisted conductors into either the #8 or the 5/16" ring terminal until it stops. Using a crimping tool, crimp the wire in place in the barrel. Connect the ring terminal to the chassis by putting the 5/16" ring terminal under an existing bolt, or by screwing a #8 self tapping screw into a 9/64" hole in the chassis.

### Positive Chassis Electrical Connection

**Black Wire:** Strip 0.250" - 0.375" (1/4" to 3/8") of insulation off the end of the black wire. Twist the conductor strands together. Insert the twisted conductors into the supplied red female quick connect terminal until it stops. Where the wire goes into the crimp connector, the wire goes through a large barrel and then a small barrel. Using a crimping tool, crimp the wire in place in the small barrel. Next, crimp the outer most barrel (the large barrel) for mechanical strength.

**Red Wire:** Strip 0.250" - 0.375" (1/4" to 3/8") of insulation off the end of the red wire. Twist the conductor strands together. Insert the twisted conductors into either the #8 or the 5/16" ring terminal until it stops. Using a crimping tool, crimp the wire in place in the barrel. Connect the ring terminal to the chassis by putting the 5/16" ring terminal under an existing bolt, or by screwing a #8 self tapping screw into a 9/64" hole in the chassis.

### Assemble Power Connection

To connect the power wire, snap the included blue t-tap around the vehicle's brake light wire where you want to get the power. To do this, place the wire in the open channel as shown in Figure 15. Fold the connector body until the metal element contacts the wire, and crimp the connector closed with a pair of pliers. Push one end of the white fuse holder into the female slot of the t-tap. Push the red female quick disconnect onto the opposite end of the white fuse holder. Insert the fuse into the fuse holder. Re-connect the vehicle's battery.

## REPLACEMENT PARTS GUIDE

P.N.	NAME	DESCRIPTION	PRICE
236-508	Fuse	2 each, ATO 1 amp blade fuses	1.95

Prices are in U.S. Dollars, are subject to change, and do not include shipping or handling charges. To order, call your Logo Lites dealer, or call the Consumer Hot Line shown on the front of this manual.

## TROUBLE SHOOTING

Cause	Test	Solution
Disconnected or dead battery	Check if head lights work	Connect battery, clean terminals, or charge
Bad brake light switch or vehicle fuse	Check if regular brake lights work	Check fuse or replace brake light switch
Incorrect wiring	Check against instructions in Step 4	Re-wire as stated in Step 4
Blown third brake light fuse	Remove fuse and test	Check wire for abrasions or short to chassis. Replace fuse. <b>Unit can safely use 1, 2, or 3 Amp fuse.</b>
Bad chassis connection	Run wire from battery's chassis connection to third brake light chassis connection	Clean chassis connection/relocate chassis connection
Bad connections	Check all connections from vehicle wiring to third brake light	Fix or clean bad connections

If you have confirmed that none of the above are causing the third brake light not to illuminate, call the Consumer Hot Line shown on the front of this manual.

## LIMITED WARRANTY

Creative Connections, Inc. (hereinafter "CCI") warrants to the Purchaser of this unit that this unit will be free of defects in workmanship and materials for a period of one (1) year from the date of purchase. "Defects" as used herein, refer only to those imperfections which impair the utility of the product. Defective units reported or returned to CCI within one (1) year from date of purchase will be exchanged or repaired without charge at the option of CCI.

This warranty is limited to the repair or exchange of the product and does not cover and CCI will not pay nor provide any other benefit or service including labor or materials which may be necessary to remove or replace a defective unit. CCI shall not be liable for any injury, loss or damage, direct or consequential, arising out of the use or failure of this product. It is the user's responsibility to determine the suitability of this product for its intended use. User assumes any and all risk or liability in connection with the installation and use of this product. This warranty does not apply to any defects resulting from abuse, negligence, intentional damage, modification, improper installation, unreasonable use, exposure to elements, or over-tightening of fasteners.

Defective units should be reported directly to CCI and not to your retailer. Contact CCI through the Consumer Hot Line through the telephone number shown on the front of this manual or write to the address shown on the front of the manual. Identify the Logo Lites product purchased, the date and location of purchase, and the nature of the alleged defect. Do not ship your product back to CCI unless and until specifically directed to do so. Shipping instructions will be provided to you at the appropriate time. All defective products returned must be accompanied by proof of purchase.

This warranty is not transferable and applies only to products sold within the United States of America, the District of Columbia, the Commonwealth of Puerto Rico, territories of the United States, and Canada.

**THIS LIMITED WARRANTY IS IN LIEU OF ALL OTHER EXPRESS WARRANTIES. CCI SHALL NOT BE LIABLE TO ANY SPECIAL, INCIDENTAL OR CONSEQUENTIAL DAMAGES. ANY IMPLIED WARRANTY OF FITNESS FOR A PARTICULAR PURPOSE, MERCHANTABILITY OR OTHERWISE, APPLICABLE TO THIS PRODUCT, SHALL BE LIMITED IN DURATION TO THE DURATION OF THIS LIMITED WARRANTY.** Some states do not allow the exclusion or limitation of incidental or consequential damages, so the above limitation or exclusion may not apply to you.